**Subject: PowerGrip® Kit K015541XS for Ford 1.8 diesel engines**

Since the launch of our K015541XS during 2003, this kit has always contained an automatic tensioner for these Ford 1.8 diesel applications.

The very first models of the Ford Focus and Ford Fiesta, however, were initially equipped with a manual tensioner. Very shortly after the introduction of these vehicles, Ford decided in July 2000 to replace the manual tensioner by a new automatic tensioner. All cars originally equipped with the manual tensioner had to be refitted with an automatic tensioner.

Most of the manual tensioners have been replaced by the automatic one, so only a limited number of drive modifications should be expected. If you should encounter a vehicle that still needs the initial installation of the modified tensioner, there is no problem to do the replacement with our K015541XS.

Doing a timing belt kit replacement from a manual tensioner to the automatic one, however, still involves some additional points to check.

**Attention points!****1. Automatic tensioner**

Fig. 1

**New automatic tensioner****Old manual tensioner**

Fig. 1 shows the old manual tensioner on the right side and the new automatic tensioner on the left.

# Business Development

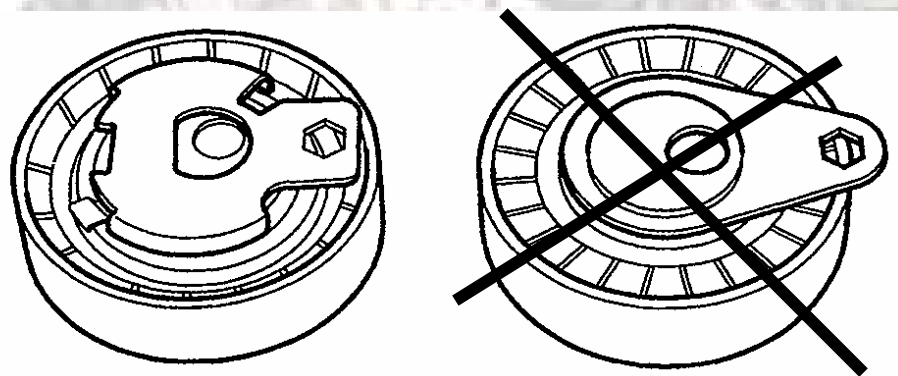
## European Aftermarket

### 2. Camshaft pulley

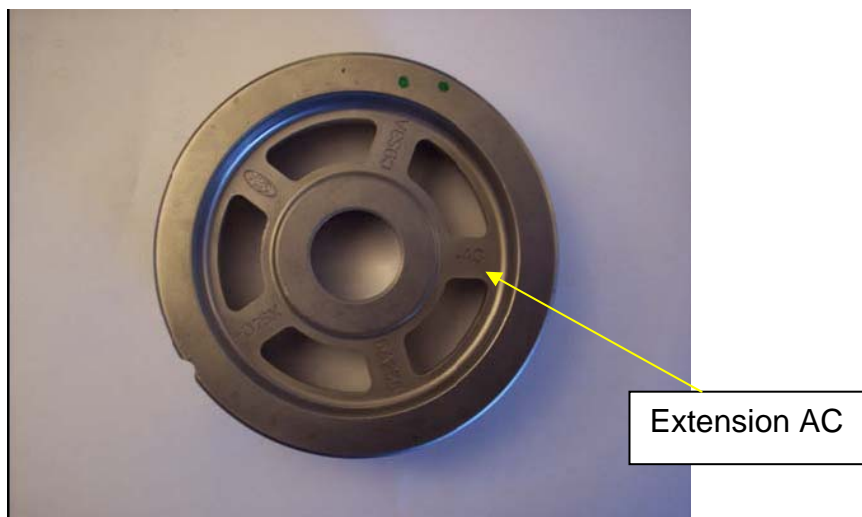

Fig. 2

Check if the part number of the camshaft pulley ends with **AC** (Fig. 2). Should the part number of the camshaft pulley end with **AB**, fit new sprocket with OE ref. XS4Q6A256**AC**. Please note that Gates advises to check the version of the camshaft pulley during **any replacement** of this type of vehicle.

### 3. Timing belt cover

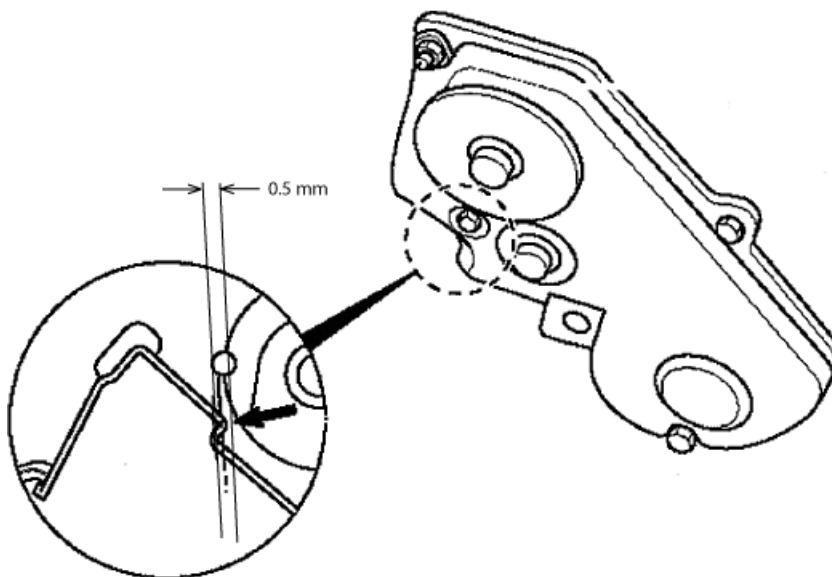

Fig. 3

# Business Development

## European Aftermarket

# Technical Bulletin

When the manual tensioner is replaced by an automatic tensioner, the timing belt cover has to be modified.  
File off the inner corner (0.5 mm) as shown in Fig. 3. *Do not damage the timing belt cover by filing off too much of the corner!*

Ignoring the above guidelines can seriously damage your engine!

Should you have any further questions or remarks, please don't hesitate to contact us.

Sidney Paerewijck  
Product specialist  
Tensioners & kits

[sidneyp@gates.com](mailto:sidneyp@gates.com)  
Tel: +32 53 762 864  
Fax: +32 53 762 715